

REPUBLIC OF SOUTH AFRICA

REGISTER OF PATENTS

PATENTS ACT, 1978

OFFICIAL APPLICATION NO.		LODGING DATE: PROVISIONAL	ACCEPTANCE DATE
21	01	919350	22
INTERNATIONAL CLASSIFICATION		LODGING DATE: COMPLETE	GRANTED DATE
51	COLB	23	27th November, 1991
			1992-05-30

FULL NAME(S) OF APPLICANT(S)/PATENTEE(S)

71

MINTEK . A legal body organised and existing under the laws of the Republic of South Africa.

APPLICANTS SUBSTITUTED:

71

DATE REGISTERED

ASSIGNEE(S)

71

DATE REGISTERED

FULL NAME(S) OF INVENTOR(S)

72

Lourens Jacobus ERASMUS, Albert Francois Simon SCHOUKENS.

PRIORITY CLAIMED	COUNTRY	NUMBER	DATE
N.B. Use International abbreviation for country (See Schedule 4)	33	ZA	31
		90/10260	32
			20th December, 1990

TITLE OF INVENTION

54

THE PRODUCTION OF CALCIUM CARBIDE.

ADDRESS OF APPLICANT(S)/PATENTEE(S)

200 Hans Strijdom Drive, Randburg, Transvaal, Republic of South Africa.

ADDRESS FOR SERVICE

74

JOHN & KERNICK, VAN DER STEL BLDG., PRETORIUS STR., PRETORIA

J & K REF:

P 11372 ZA

PATENT OF ADDITION NO.

61

DATE OF ANY CHANGE

H 57.

n. word.

ohn & Kernick
FORM P7

COMPLETE SPECIFICATION

(Section 30(1) - Regulation 28)

01	Official application No. 919350	22	Lodging date 27th November, 1991	J&K Reference P 11372 ZA/MvS
International classification C01B				

Full Name(s) of Applicant(s)
MINTEK . A legal body organised and existing under the laws of the Republic of South Africa.

Full name(s) of Inventor(s)
Lourens Jacobus ERASMUS, Albert Francois Simon SCHOUKENS.

Title of invention
THE PRODUCTION OF CALCIUM CARBIDE.

Blank area for drawing or additional text.

- 2 -

"THE PRODUCTION OF CALCIUM CARBIDE"

FIELD OF THE INVENTION

THIS INVENTION relates to the production of calcium carbide and, more particularly, to the thermal production of calcium carbide from solid calcium containing materials such as calcium oxide, 5 dehydrated calcium hydroxide, and other related calcium compounds, together with a carbonaceous reductant.

/Still more

Still more particularly the invention is concerned with the production of calcium carbide of a grade which is particularly suitable for use in the production of acetylene and wherein the calcium units, once the calcium carbide is used for the production of acetylene, may, if required, be recycled to the process to regenerate calcium carbide.

BACKGROUND TO THE INVENTION

Numerous different processes have been proposed, and are in commercial use, for the production of calcium carbide.

The traditional process for producing calcium carbide is the heating of lumpy calcium oxide and lumpy anthracite in a submerged arc furnace at a temperature of about 1950°C. The difficulties associated with such a process are that fine and easily friable feedstocks can only be handled with difficulty. The sizing of the feed material is, accordingly, fairly critical. Temperature control is difficult and local overheating often occurs

/which can

(which can cause furnace eruptions and the production of calcium metal, which adversely affects the carbide yield. This traditional process generally results in a calcium carbide product containing no better than about 75-80% active calcium carbide (measured by its acetylene generating capability).

In consequence of this, various processes have been proposed which employ a thermal plasma as the heat source in order to conduct the required reaction.

Thus, German Democratic Republic Patent No. 136824 describes a process in which calcium oxide is heated, to above melting point (about 3000°K) and then contacted with hydrocarbons. This patent also describes a process in which waste gases are used to preheat the feed materials to thereby conserve energy.

Japanese Patent No. 63/112409 describes another process in which a plasma flame is employed. In this case calcium containing substances are vaporised and contacted with a reductant gas in a

/gas phase

gas phase reaction. Applicant is unaware of the success or otherwise of this process but believes that the formation of a vaporised calcium containing substance to be impractical on a commercial scale.

South African Patent No. 83/9474 describes a plasma process in which the plasma flame acts on a descending burden of charge which descends from the roof of the furnace. There may be a subsidiary inlet for finely divided carbon. Once again the gases generated serve to preheat the burden by direct contact therewith.

United States Patent No. 3,404,078 also employs a plasma arc to produce calcium carbide which, in this case, is produced on the surface of graphite particles constituting a fluidised bed thereof. Subsequent separation of the calcium carbide, attendant loss of graphite, and an apparently low degree of reaction, render this process, applicant believes, also commercially undesirable.

/South African

South African Patent No. 85/5475 furthermore describes a plasma arc furnace wherein a concentric annular burden of coarse particles descends around the inner walls of the furnace and fine grain particles are added in a central region. Again, the off-gases contact the "burden" to preheat it.

South African Patent No. 83/3773 also describes a plasma production process and wherein, once more, the reaction chamber is surrounded on all sides by solid reducing agent. In this case carbon powder and powdered calcium oxide or limestone are employed as the feed materials.

South African Patent 83/9475 furthermore describes a plasma torch operated furnace, once more one in which the feed stock is fed in an annular configuration as a protective layer to the furnace bath. The feed material is again preheated by contact with the off-gases.

The presence of impurities, in particular, Al_2O_3 and SiO_2 , in the product calcium carbide can have a deleterious effect on the acetylene producing

/characteristics of

(characteristics of the carbide, due to entrainment in the grains thereof. Not only this, but such impurities also lead to the situation that spent calcium hydroxide emanating from the acetylene
5 production process cannot practically be recycled as it carries with it too many impurities. These, added to impurities freshly introduced into the process, renders such recycling impractical.

Applicant believes that all of the processes
10 outlined above which embody the use of a burden of solid feed material have the disadvantage in that vaporised impurities, such as those identified above, become deposited, at least to some extent, on the feed material and therefore are carried back
15 into the reaction zone. This being so, the impurity level in the calcium carbide produced is substantially higher than it need be in the absence of such re-introduced impurities.

It is the object of this invention to provide a
20 process for the production of calcium carbide in which a thermal plasma is employed for heating the solid reactants but wherein the calcium carbide

/produced is

produced is of high grade and contains a level of impurity low enough to enable it to be recycled after being employed for the production of acetylene by reaction with water.

SUMMARY OF THE INVENTION

5 In accordance with this invention there is provided a process for the production of calcium carbide comprising feeding a suitable solid calcium containing compound together with carbonaceous reductant to a thermal plasma heated furnace, the
10 process being characterised in that substantially all of the calcium containing compound and carbonaceous reductant are added directly to a molten bath of material in the hearth of the furnace at a controlled rate chosen to maintain the
15 molten condition to such bath.

Further features of the invention provide for the temperature of the molten bath to be between 1950°C and 2150°C, and preferably between 2000°C and 2100°C; for the process to be carried out in a
20 plasma furnace having an electrode (preferably used

/as the

as the cathode) extending downwardly from the roof of the furnace and wherein the molten bath of material forms an electrical connection to a counter electrode (preferably used as the anode) associated with the base of the bath; for the plasma generating electrode to include a hollow electrode through which some or all of the reactants are introduced to the molten bath of material; for the temperature of said bath to be controlled to ensure vaporisation of impurities to the extent required to provide a desired low level thereof in the calcium carbide produced; and for the off-gases from the furnace, in the event they are employed for preheating feed materials, to be treated for the removal of such impurities prior to contact with such feed materials.

It has been found that by employing the process of this invention, not only can the impurity level in the product calcium carbide be minimized, but also use of the process of this invention enables low grade raw materials to be used and also materials of fine particulate size.

/By using

By using the present invention, and by controlling the relative amount of carbonaceous reductant and calcium containing material, which is conveniently either calcium oxide, dehydrated calcium hydroxide, or limestone, an extremely good grade of calcium carbide, with limited undesirable impurities, can be produced. The temperature of production will generally be between 2000°C and 2150°C and production takes place most expediently at atmospheric pressure. The off-gases from the furnace, which include a large amount of carbon monoxide, can, after removal of undesirable impurities, be employed for preheating of the feed.

In order that the invention may be more fully understood experimental test work will now be described with reference to the accompanying drawings.

BRIEF DESCRIPTION OF THE DRAWINGS

In the drawings :-

/FIG. 1 is

FIG. 1 is a schematic diagram of a pilot plant plasma furnace assembly; and,

FIG. 2 is a graph showing increase in calcium carbide grade produced as a function of the tapping temperature.

DETAILED DESCRIPTION OF EXPERIMENTAL TEST WORK

In order to demonstrate the efficacy of the invention, the production of calcium carbide from two different starting materials was carried out. The one starting material, termed herein "calcined limestone", is the conventional starting material for the production of calcium carbide by the prior art processes.

The other starting material, termed herein "dehydrated calcium hydroxide", is the residual dehydrated calcium hydroxide obtained after reaction with water of calcium carbide produced by the conventional method. The dehydrated calcium hydroxide is thus the material which is normally considered to be incapable of being recycled in

/view of

view of the fact that it contains excessive quantities of impurities, in particular SiO_2 and Al_2O_3 .

5 The equipment employed for carrying out the tests is illustrated schematically in Figure 1 and comprised a furnace, generally indicated by numeral 1, having a refractory lined cylindrical shell, a truncated conical roof 2 and a flat roof section 3 closing the smaller end of the conical roof 2. The
10 furnace shell was lined with graphite packed with 98% magnesia refractory powder.

15 The conical and flat roofs used in combination with the furnace were water cooled and lined with silicon carbide castable material. The plasma generating electrode 4 was a hollow tubular graphite electrode which passed through a magnesia plug (not shown) in the flat roof section. An off-gas port 5 was provided in the conical roof section.

20 The counter electrode (in this case used the anode) was located centrally in the bottom of the furnace.

/The feeder

The feeder arrangement consisted of a screw feeder 7 arranged to feed into a discharge tube 8 communicating directly with the tubular graphite electrode. The screw feeder was in turn fed from a hopper 9 (the feed materials in this hopper provided the required seal between the furnace and atmosphere) supplied from a transfer bin 10.

The furnace described above, (which had a size of 0,9m internal diameter and an internal of 0,95m), was operated on a 24 hour basis for a total period of 12 days in order to conduct the required tests. In the case of the one type of feed material, namely the calcined limestone, it was mixed with anthracite fines prior to being fed to the furnace. The other feed material, namely dehydrated calcium hydroxide was briquetted with anthracite and sized at 100% minus 8mm, 80% minus 6mm, and 100% plus 2mm. The anthracite was present in a quantity calculated to provide 40% carbon in the feed based on the calcium oxide content only.

Heat dissipated through the furnace walls and roofs was calculated. The feed rate in each case was

/determined for

determined for a selected power level of the furnace, taking the calculated losses into consideration, and the feed rate was controlled to maintain the required temperature in the furnace bath at the predetermined power level. The temperature of the calcium carbide being tapped from the furnace was monitored using an optical pyrometer. In each case the grade of the calcium carbide produced was determined using the gas yield method in which the amount of acetylene generated from the calcium carbide was measured. A chemical analysis of the residual calcium hydroxide was also determined after dehydration of the calcium hydroxide.

The gas and dust from the furnace was cleaned in a bag filter, after combustion with excess air, for safety reasons.

During the smelting campaign a total of eleven tons of material was processed. The tap size varied between 100 and 500 kg carbide each. The furnace was operated between at 300 kW and 600 kW and, for short periods, at 800 kW.

/The chemical

The chemical analysis for the starting materials, namely calcined limestone and dehydrated calcium hydroxide, are given below in Table 1:-

TABLE 1

	Calcined limestone	Dehydrated* Ca(OH) ₂
CaO	93.93	80.08
SiO ₂	1.05	4.69
Al ₂ O ₃	0.33	2.01

*By-product of conventional calcium carbide process.

5 Five runs in which calcined limestone was used as the starting material together with anthracite, in the mixture indicated above, gave the results shown in Table 2 below.

TABLE 2

No	Feed	Carbide Produced		
	kg	kg	Tapping temp. °C	Grade % CaC ₂
1	441	253	1830	59.7
2	133	72	1880	69.3
3	219	122	2011	87.3
4	488	264	2090	89.3
5	454	253	2142	93.5

It will be noted that high tapping temperatures are associated with high grades of carbide product, this reaching 93,5% in the case of the temperature of 2142°C and 89,3% at a temperature of 2090°C.

5 Four tests were carried out using dehydrated calcium hydroxide briquetted with the necessary anthracite. These tests were conducted at different temperatures and the results are shown in Table 3 below.

TABLE 3

No	Feed		Carbide Produced	
	kg	kg	Tapping temp. °C	Grade
				% CaC ₂
6	556	225	1969	74.0
7	591	330	2017	76.1
8	481	291	2040	82.4
9	610	358	2071	88.5

10 It will be noted that the grade of the calcium carbide product again increased as the tapping temperature increased.

/The analysis

The analysis of the dehydrated calcium hydroxide obtained from the calcium carbide product after acetylene generation and dehydration are given below in Table 4.

TABLE 4

Chemical analyses, % by mass			
No.	CaO	SiO ₂	Al ₂ O ₃
1	81.04	3.46	2.62
2	80.71	2.25	1.43
3	85.78	2.04	1.11
4	87.99	1.83	0.96
5	92.66	1.60	0.84
6	79.99	2.80	3.10
7	83.97	1.28	1.38
8	84.24	1.18	1.38
9	85.80	1.60	1.11

5 The CaO content of the dehydrated calcium hydroxide (the product of the conventional process) was 80,08% which, in general, is lower than the values given in Table 4.

10 It is to be noted that the calcium oxide content of the calcium hydroxide formed after acetylene production using carbide produced by the present invention, has a higher grade and lends itself to

/recycling when

recycling when compared to residual calcium hydroxide produced after acetylene production from carbide resulting from the conventional process.

5 With the use of the above and other results, the graph shown in Figure 2 has been compiled which gives a direct indication of the calcium carbide grade to be expected at the various temperatures when the process of this invention is employed. It will be seen that temperatures of about 2050 to 2100°C will
10 give the highest yield of calcium carbide since higher temperatures generally result in losses of calcium.

1 The invention therefore provides a simple, yet highly effective, process for the production of calcium
15 carbide which provides an improved grade of calcium carbide as well as the facility of recycling most of the calcium units which was not possible in the case of prior art conventional process.

WHAT IS CLAIMED IS:-

1. A process for the production of calcium carbide comprising feeding a suitable solid calcium containing compound together with carbonaceous reductant to a thermal plasma heated furnace, the process being characterised in that substantially all of the calcium containing compound and carbonaceous reductant are added directly to a molten bath of material in the hearth of the furnace at a controlled rate chosen to maintain the molten condition to such bath.
2. A process as claimed in claim 1 in which the temperature of the molten bath is between 1950°C and 2150°C.

/3. A process

3. A process as claimed in claim 2 in which the temperature of the molten bath is between 2000 and 2100°C.
- 5 4. A process as claimed in any one of the preceding claims in which the furnace has an electrode extending downwardly from the roof of the furnace and wherein the molten bath of material forms an electrical connection to a counter electrode associated with the base of
10 the bath.
5. A process as claimed in claim 4 in which the electrode extending downwardly from the roof is the anode.
- 15 6. A process as claimed in any one of the preceding claims in which the plasma generating electrode includes a hollow electrode through which some or all of the reactants are introduced to the molten bath of material.

/7. A process

7. A process as claimed in any one of the preceding claims in which the temperature of the bath is controlled to ensure vaporisation of impurities to an extent required to provide a desired low level thereof in the product calcium carbide.

8. A process as claimed in any one of the preceding claims in which the off-gases are treated for the removal of dust which contains impurities including SiO_2 and Al_2O_3 .

9. A process as claimed in claim 8 in which the treated off-gases are used to preheat feed materials.

10. A process substantially as herein described and exemplified.

DATED THIS 27 DAY OF NOVEMBER 1991

N. B. SWART
JOHN & KERNICK
FOR THE APPLICANT

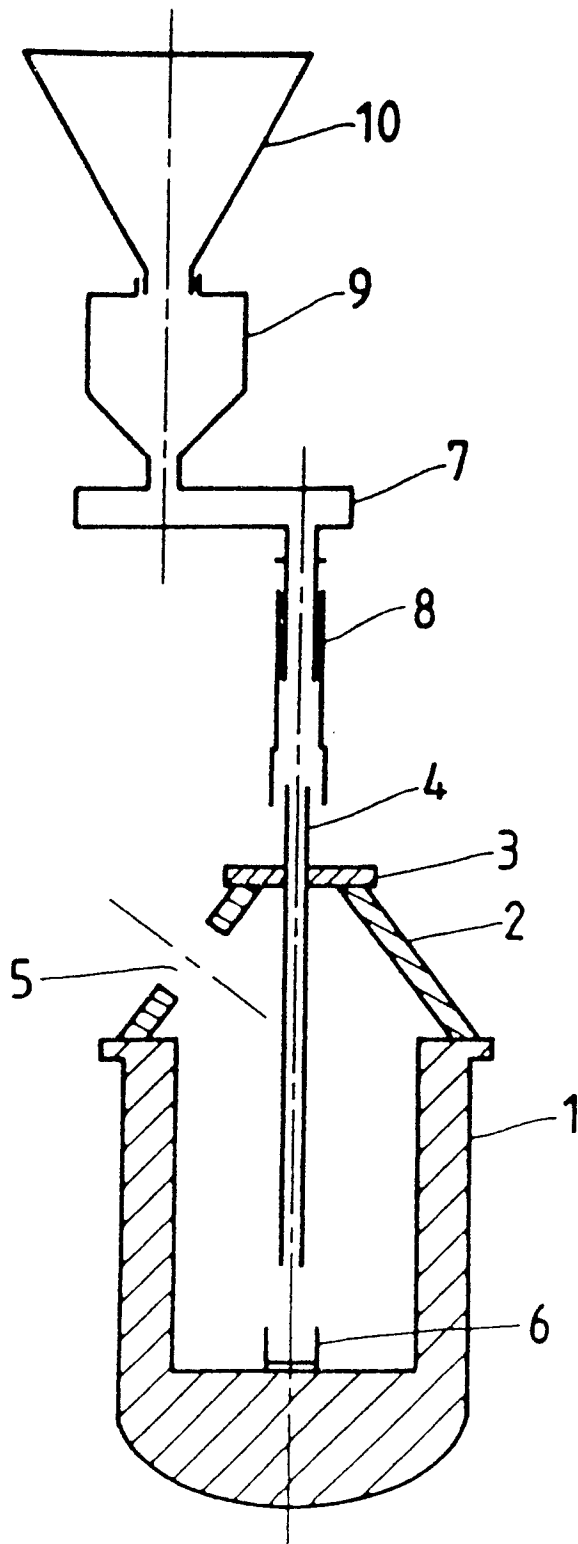

FIG. 1

N. B. SWART
JOHN & KERNICK
For the Applicant

