

John & Kernick

REPUBLIC OF SOUTH AFRICA  
PATENTS ACT, 1978

FORM P 7

# Complete Specification

(Section 30(1) — Regulation 28)

21 01	Official application No.	22	Lodging date	J&K reference
	83/1374		1983 -03- 01.	P.8761 MvS
51	International classification			
	C25b H01m			
71	Full Name(s) of applicant(s)			
	COUNCIL FOR MINERAL TECHNOLOGY			
72	Full Name(s) of inventor(s)			
	NICHOLAS ADRIAN BARCZA JOHN FRANCIS MOONEY			
54	Title of invention			
	"THE PROTECTION OF WATER COOLED PLASMA GENERATING DEVICES"			

BACKGROUND TO THE INVENTION

THIS INVENTION relates to the protection  
of water cooled electrode assemblies for thermal  
plasma generating devices, often termed "plasma  
5 torches" or "guns" of the general type comprising  
a water cooled electrode about which an annular  
cross sectioned passage for gas is defined by a  
water cooled outer sheath.

10 In the above type of plasma generating  
devices (which are essentially of the non-consumable  
electrode type), the geometry of the gas outlet  
defined between the free end of the electrode and  
the water cooled outer sheath can be determined  
15 according to requirements. This feature results  
from the non-consumable characteristic of the  
electrode assembly as opposed to a consumable type  
of electrode wherein the geometry of the gas

/...

outlet varies according to the pattern in which consumption of the electrode takes place, eg. a hollow graphitic electrode.

5 One disadvantage of the non-consumable water cooled electrode assembly outlined above is that, when used to generate transferred-arcs, they are susceptible to damage by what is often termed "stray arcing". Such stray arcing results from the fact that a flow of electrical energy is generated  
10 along a path other than the water cooled cathode itself which is designed for that purpose. In fact, measurements have shown that the voltage between the sheath and cathode indicate that the potential of the sheath is close to that of the cathode in many  
15 cases.

Various attempts have been made to suppress such "stray arcing" and these attempts have been directed towards increasing the resistance of the path between the cathode and the anode via the  
20 sheath. Such attempts have included the provision of refractory coatings on the sheath but such coatings suffer from thermal shock and are thus not completely satisfactory.

Accordingly this problem remains, as far as the applicant is aware, unsolved, with the consequence that such outer sheaths are susceptible to the burning of holes through them by the stray arcing. The formation of such holes renders the entire electrode assembly inoperable and vulnerable to the heat surrounding it as a result of the loss of cooling. The consequence is that the entire electrode assembly is usually damaged beyond repair or requires substantial repairs.

It is the object of this invention to provide a solution to the problem without necessitating the electrical isolation of the electrically conductive water cooled sheath which has, as indicated above, not met with any great degree of success.

In the specification the term "high melting point" when applied to a material is intended to mean a material which has suitable high temperature properties, that is to say it does not melt or sublime below 2000°. It will be noted that this term extends to materials which may sublime instead of melting.

BRIEF SUMMARY OF THE INVENTION

In accordance with this invention there is provided a plasma generating electrode assembly comprising a water-cooled electrode located within, but spaced apart from, a water-cooled conductive metal sheath wherein a gas flowpath is defined between the sheath and electrode with an outlet at its free end, the plasma gun being characterised in that the sheath has, at least on a substantial portion of its outer surface, a high melting electrically conductive layer adapted to attract any stray arcing to itself rather than to the outer sheath directly, the thickness of the high melting conductive material providing dispersion of heat energy generated by stray arcing.

Further features of the invention provide for the high melting conductive layer to be made of a suitable graphitic material and, in particular, for the layer to be composed of a prefabricated, optionally longitudinally split, sleeve of solid graphite material held in electrical contact with the outer surface of the sheath.

It will be understood that the extent of contact required between the outer layer and the conductive sheath will depend, to a large extent, on circumstances and may vary from application to application. Thus, in many cases, it may be sufficient for good electrical contact to take place only at one end, for example the end remote from the free end of the cathode assembly in order to dissipate electrical energy received by the layer as a result of stray arcing. In such a case care must be taken that internal arcing between the layer itself and the outer surface of the sheath should not take place in areas where there is not direct contact between the layers and the sheath.

The invention also envisages the provision of a sleeve of substantially greater internal diameter than the external diameter of the sheath with which the sleeve is to co-operate and the provision of an intermediate packed and optionally settable layer of conductive material between such sheath and sleeve. Such material could also be based on a graphite composition.

/...

It may be found, in use, that the sleeve or layer tends to become consumed and, in such a case, it may be possible to render the sleeve or layer movable relative to the outer surface of the sheath so that it can be moved down the outer sheath or adjust its axial position and ensure that the operative end of the electrode assembly is protected adequately.

The invention also provides prefabricated elements adapted to define, in combination with a non-consumable plasma generating electrode assembly, an assembly as defined above.

#### BRIEF DESCRIPTION OF THE DRAWINGS

In order that the invention may be more fully understood one embodiment will now be described with reference to the accompanying drawings in which:-

Fig. 1 illustrates in longitudinal sectional elevation a plasma generating

/...

electrode assembly protected according to  
this invention,

and

5 Figure 2 illustrates one form of a  
longitudinally split graphite sleeve  
envisaged according to this invention.

DETAILED DESCRIPTION WITH REFERENCE TO THE DRAWINGS

Referring firstly to Fig. 1, a plasma  
generating cathode assembly of a conventional  
10 water-cooled type comprises a water-cooled cathode 1  
located concentrically within, but spaced apart  
from, a water-cooled outer sheath 2. The annular  
cross-sectioned passage 3 defined between the  
cathode and the sheath provides the required flow  
15 path for gas and the free ends 4 and 5 of the  
cathode and sheath can each be shaped to provide the  
required geometry of the outer passage, and,  
therefore, the required flow of gas  
from the gun.

/...



The cathode and water cooled sheath are both made of an electrically conductive metal material, conveniently thoriated tungsten and copper respectively (or combinations of both) as is known in the art.

In order to obviate the possibility of damage to the outer sheath as a result of stray arcing, a sleeve 6 of solid graphite material, which has been machined to fit neatly over the sheath, is provided. In this particular embodiment of the invention the sleeve is made as a single piece by machining a solid cylindrical piece of graphite. Clearly the tolerance is such that a satisfactorily large area of the graphite is in contact with the outer surface of the sheath so that electrical and thermal energy received by the graphite sleeve is dissipated to the sheath over a sufficiently large area to obviate any damage to the sheath.

The thickness of the graphite sleeve is chosen accordingly and, whilst no optimisation or other calculations have been effected in order to determine the optimum or minimum thickness of the

/...

sleeve, it is envisaged that a thickness of preferably between five and twenty-five millimeters (or larger) will provide the desired results with even thicker sleeves being employed on larger plasma  
5 generating electrode assemblies.

The sleeve may terminate short of the substantially solid nozzle end of the sheath as illustrated, but may also extend up to or beyond the extremity of the outer surface of the sleeve as  
10 indicated in dotted lines by numeral 7. It may, indeed, be required that the end face or a part thereof be covered by the sleeve material and such an arrangement, which is indicated in dotted lines  
15 by numeral 8, also falls within the scope of this invention.

In one practical test which has been conducted according to the invention, a conventional plasma generating electrode assembly of the water cooled, non-consumable type, and with a water cooled  
20 sheath made of copper, was provided with a graphite sleeve as described above. Stray arcing was induced by means of a conducting probe connected to the anode by means of a flexible

cable and with which stray arcing was artificially induced. Absolutely no damage resulted to the electrode assembly even when a dead short circuit on the side of the sleeve was made.

5                   It will be understood that numerous variations may be made to the above described specific electrode assembly with the graphite sleeve and, in particular, it is envisaged that the sleeve may be longitudinally split in order to avoid  
10 difficulties which may otherwise occur in accurately machining a solid piece of graphite to contact the outer surface of a water cooled conductive sheath. Thus, there is envisaged a longitudinally split sleeve of the type indicated in Fig. 2 in which two  
15 halves 9 have longitudinally extending edges 10 which are rebated to co-operate with each other and provide a stepped split in cross-section.

                  Numerous other possibilities fall within the scope of the invention including the application  
20 of settable mixes of suitable conductive materials,

/...

in particular graphite or other carbon materials, to  
the surface of the water cooled conductive sheath of  
an electrode assembly. Also it may be sufficient to  
provide a series of closely spaced strips, either  
5 straight, circular or helical in shape, of high  
melting conductive material on the outer surface of  
the sheath. In such a case the spacing would  
obviously be critical to the effectiveness of the  
strips.

10 The invention therefore provides a useful  
yet simple and inexpensive method and means for  
preventing damage to the outer sheath of water  
cooled plasma generating electrode assemblies  
through the effects of stray arcing. In addition,  
15 the invention provides a layer of lower thermal  
conductivity on the surface of the  
sheath which means that less heat would in fact  
arrive at the copper surface. This results in a  
decreased cooling requirement for the sheath.

/...

CLAIMS

1. A plasma generating electrode assembly comprising a water-cooled electrode located within, but spaced apart from, a water-cooled conductive metal sheath wherein a gas flowpath is defined between the sheath and electrode with an outlet at its free end, the plasma gun being characterised in that the sheath has, at least on a substantial portion of its outer surface, a high melting electrically conductive layer adapted to attract any stray arcing to itself rather than to the sheath directly, the thickness of the high melting conductive material providing dispersion of heat energy generated therein by stray arcing.

/...

2. A plasma generating electrode assembly as claimed in claim 1 in which the high melting, electrically conductive layer is made of a suitable graphitic material.
  
- 5 3. A plasma generating electrode assembly as claimed in claim 2 in which the layer is composed of a prefabricated sleeve of solid graphite material held in substantial electrical contact with the outer  
10 surface of the sheath.
  
4. A plasma generating electrode assembly as claimed in claim 3 in which the sleeve is split longitudinally.
  
- 15 5. A plasma generating electrode assembly as claimed in any one of the preceding claims in which the said electrically conductive layer extends over only selected parts of the surface area of the sheath.
  
- 20 6. A plasma generating electrode assembly as claimed in any one of the preceding claims in which the said

electrically conductive  
layer is composed, at least in part, of  
settable material contacting the sheath.

5 7. A plasma generating electrode assembly as  
claimed in any one of the preceeding  
claims in which the said conductive layer  
is axially adjustable in position on the  
sheath.

10 8. A plasma generating electrode assembly as  
claimed in claim 1 or substantially as  
herein described or exemplified with  
reference to Fig. 1 alone or Figs. 1 and  
2 jointly of the accompanying drawings.

DATED this 1st day of MARCH, 1983

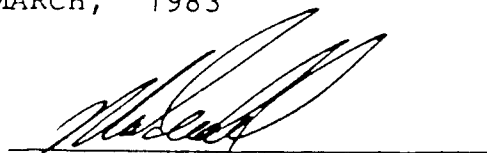

---

JOHN & KERNICK  
for the Applicant

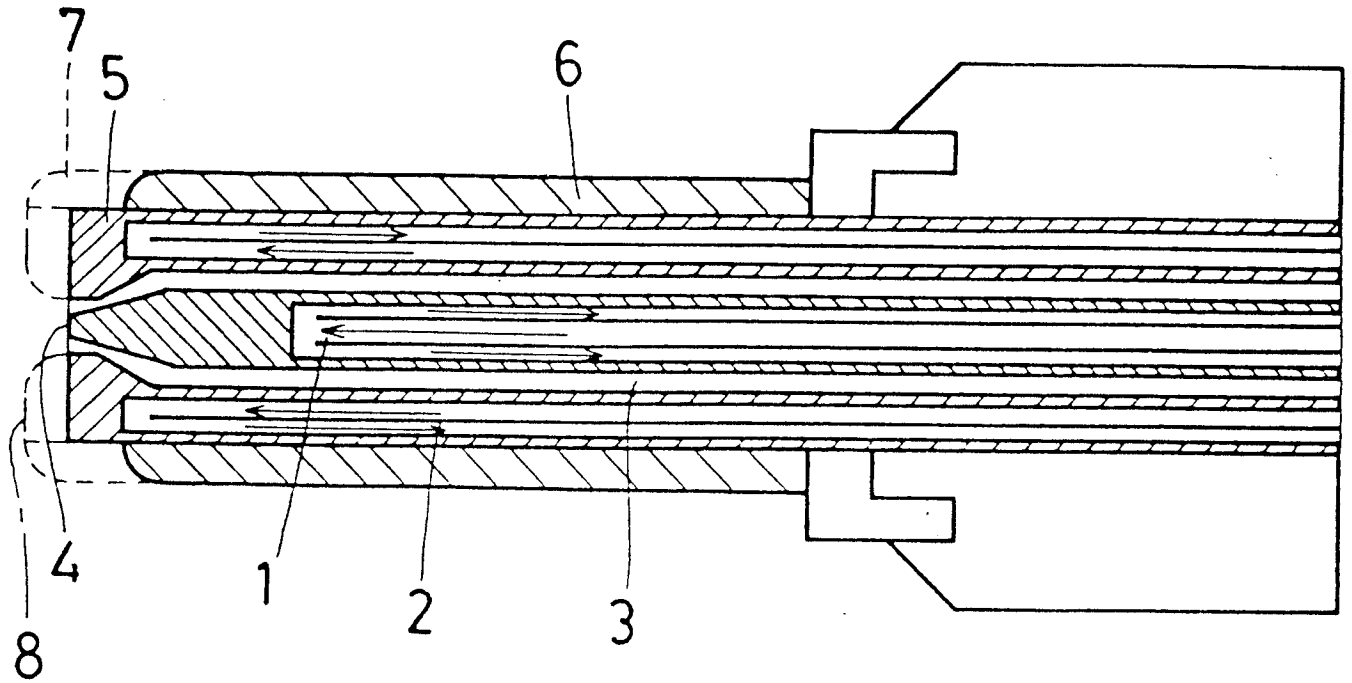

FIG. 1

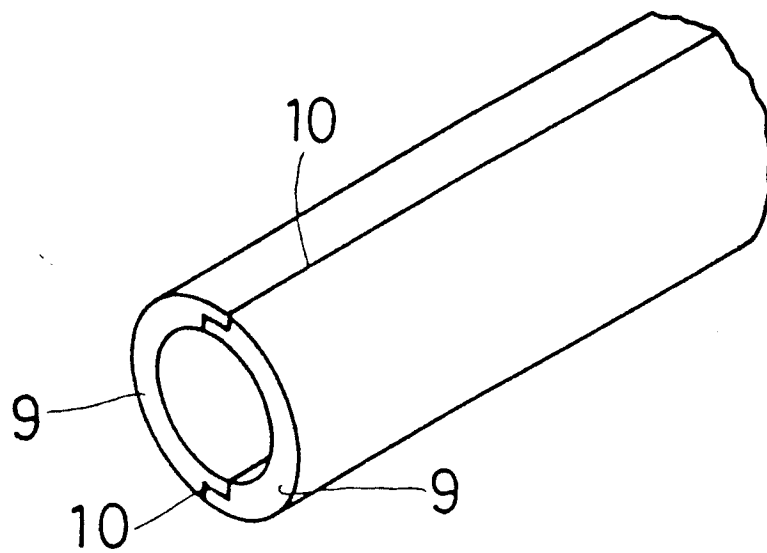

FIG. 2

  
JOHN & KERNICK  
for the Applicants