

The Enviroplas process for the treatment of steel-plant dusts*

by A.F.S. Schoukenst, F. Shawt, and E.C. Chemaly†

SYNOPSIS

Steel-plant dusts are hazardous waste materials, containing toxic constituents such as lead, cadmium, and hexavalent chromium. These dusts can be treated by a number of thermal processes, which are described as used in Western Europe and the USA. A detailed description is then given of the thermal Enviroplas process, which was developed at Mintek and produces disposable slag and valuable byproducts such as ferroalloys containing chromium and nickel, and fumes high in zinc oxide.

SAMEVATTING

Staalanaallegstof is gevaarlike afvalmateriaal wat giftige bestanddele soos lood, kadmium en heksavalente chroom bevat. Hierdie stof kan behandel word deur 'n aantal termiese prosesse wat beskryf word soos hulle in Wes-Europa en die VSA toegepas word. Daarna volg 'n uitvoerige beskrywing van die termiese Enviroplas-proses wat Mintek ontwikkel het en wat wegdoenbare slakke en waardevolle nuweprodukte soos ferrolegerings met chroom en nikkel, en dampe met 'n hoë sinkoksiedinhoud lewer.

INTRODUCTION

During steelmaking in electric-arc furnaces (EAF), 10 to 15 kg of dust is generated per tonne of steel product. This EAF dust is usually collected as fine dust in a bag filter, or as sludge in a scrubber system. Traditionally, EAF dust has been stockpiled or dumped on landfill sites. However, the use of galvanized scrap for EAF steelmaking has increased rapidly in recent years, resulting in an increase in the levels of zinc, lead, and cadmium in EAF dust. In many countries, the dumping of EAF dust is now regarded as presenting an environmental hazard because toxic metals may be leached into drinking-water supplies, and dumping is allowed only on approved sites. In the USA, EAF dust is listed by the Environmental Protection Agency (EPA) as hazardous waste under the Resources Conservation and Recovery Act (RCRA). Recent EPA regulations require EAF dust before being dumped to be treated thermally or chemically to remove or stabilize the leachable toxic metals. The EPA has specified that dusts with a zinc content of 15 per cent or more have to be treated in a high-temperature metal-recovery (HTMR) process.

EAF dust is a mixture of very fine particles (having an average size of around 1 µm) of various metal oxides. Its main mineralogical constituents are hematite, magnetite, zinc ferrite (ZnFe₂O₄), and zincite (ZnO). EAF dusts from the production of carbon steel tend to be rich in zinc and lead, and typically contain 35 per cent iron, 25 per cent zinc, and 5 per cent lead (in the form of metal oxides). Dusts from alloy-steel making operations, such as those using argon-oxygen decarburization (AOD), contain significant amounts of chromium and nickel. These dusts

typically contain 30 per cent iron, 3 per cent zinc, 0,5 per cent lead, 12 per cent chromium, and 5 per cent nickel.

The EAF dust produced yearly in Western Europe and the USA each amounts to about 500 kt, and some 75 per cent falls into the high-zinc (more than 15 per cent zinc) category. The volume of alloy-steel dusts produced worldwide is much smaller than that of EAF dusts; the annual production in Western Europe is about 50 kt. At present, about a half of the EAF dust produced in Western Europe and the USA is being treated in a number of industrial processes. Many of these processes were reviewed recently¹.

EAF dusts and dusts from alloy-steel operations cannot be recycled direct to the EAF because of their fine particle size, and their high contents of zinc, lead, halides, and alkalis, which would create operating problems. Thermal-processing technologies that have been and are being developed for the treatment of EAF dust fall into two broad categories: fuel-based processes, and electrically-based processes. The Enviroplas process developed at Mintek belongs to the latter category. All these thermal processes are based on the reduction of selected metal oxides in the dust (e.g. ZnO, Cr₂O₃, NiO) with a carbonaceous reducing agent at high temperatures (above 1200°C). In the case of EAF dust, zinc and lead oxides are reduced to their respective metals, volatilized, and then either re-oxidized to a mixed oxide or collected as metals in a condenser. During the thermal treatment of alloy-steel dust, a ferro-alloy rich in chromium and nickel is tapped from the furnace. In both treatments (of EAF dust and alloy-steel dust), metal values are recovered (e.g. zinc, chromium, and nickel), and inert slags are produced that are suitable for landfill disposal or applications such as road building and cement additives.

The Enviroplas process is a plasma-arc furnace operation that can treat EAF dust and alloy-steel dust, or a mixture of the two. A non-toxic slag is produced, together with either a mixture of zinc and lead oxide or an alloy containing chromium and nickel. The Enviroplas process is at present

* Paper presented at the Colloquium on Environmental Issues—Recycling, which was held by the South African Institute of Mining and Metallurgy at Mintek on 14th July, 1992.

† Mintek, Private Bag X3015, Randburg, 2125 Transvaal.

© The South African Institute of Mining and Metallurgy, 1993. SA ISSN 0038-223X/3.00 + 0.00. Paper received August 1992.

being developed further to recover metallic zinc direct in a lead splash condenser connected behind the plasma-arc furnace.

THEORETICAL CONSIDERATIONS

The thermal processes for the treatment of steel-plant dusts are based on carbothermic reduction at high temperatures of selected metal oxides present in the dusts. The main objectives are to produce an innocuous disposable slag and to recover valuable metals at minimal operating costs. In the thermal processing of typical EAF dusts (i.e. high-zinc, carbon-steel dusts), the addition of a carbonaceous reducing agent is designed to reduce the zinc and lead oxides in the dusts while minimizing the reduction of the iron oxides. The advantage of this selective reduction is that carbon and energy are saved, and that less carbon monoxide is generated. Also, a smaller gas-handling system is required, and less carry-over of feed is expected at the lower gas-evolution rates. However, in order to attain a CO-to-CO₂ ratio in the gas phase that is high enough to prevent excessive back-reaction of the carbon dioxide with zinc vapour, some reduction to metallic iron is necessary when zinc condensing is practised.

Ideal equilibrium calculations, based on minimization of the free energy of a multi-component and multi-phase system, were made by use of the Mintek Pyrosim² computer program to simulate the smelting of steel-plant dusts. The simulations were conducted at a fixed temperature of 1500°C and at a pressure of 1 atm. Temperatures of around 1500°C are generally employed in industrial furnaces for the smelting of steel-plant dusts. Such a temperature is necessary to drive the reduction reactions rapidly towards completion. At much higher temperatures, the energy requirement of the process is raised significantly and undesirable side reactions, such as the vaporization of magnesium, manganese, and silicon, are enhanced. The increased refractory erosion and slag fluidity (ease of tapping) when the operating temperature is increased have also to be considered in the selection of the operating temperature.

The results of the thermodynamic simulations for a typical high-zinc EAF dust are shown in Figures 1 to 4. At a carbon addition of 75 kg per tonne of EAF dust, most of the zinc is removed from the slag, and very little iron is theoretically produced (Figures 1 and 2). The extracted zinc passes into the gas phase, which contains about 50 per cent zinc, 30 per cent carbon monoxide, and 5 per cent carbon dioxide (at a CO-to-CO₂ volume ratio of about 10). When the carbon addition is raised from 75 to 150 kg per tonne of EAF dust, the theoretical energy requirement increases from about 0,8 to 1,1 MWh per tonne of EAF dust, while the CO-to-CO₂ volume ratio in the gas increases from approximately 10 to 1000 (Figure 3). This rise in carbon addition also results in a drop in the iron oxide content of the slag from about 60 to less than 1 per cent, and an increase in the amount of metal product from 16 to 310 kg per tonne of EAF dust feed (Figure 4). When zinc is condensed from the gas phase, the temperature of the gas needs to be decreased rapidly to below 500°C in order to minimize the re-oxidation of zinc by carbon dioxide. The equilibrium curves given in Figure 5 show the temperatures at which re-oxidation starts for different CO-to-CO₂

volume ratios and different partial pressures of zinc in the gas stream. For example, at a CO-to-CO₂ volume ratio of 10 and a partial pressure of zinc in the gas of 0,3 atm, the back-reaction between zinc and carbon dioxide under equilibrium conditions occurs at temperatures below 1000°C. In practice, satisfactory zinc recoveries can be achieved at CO-to-CO₂ volume ratios in the off-gas of around 10 by use of rapid quenching in a zinc or lead splash condenser.

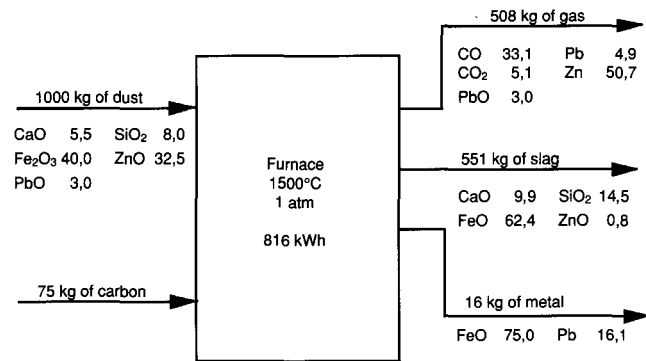

Figure 1—Predicted mass and energy balance for high-zinc EAF dust (all the analyses are given in percentages by mass)

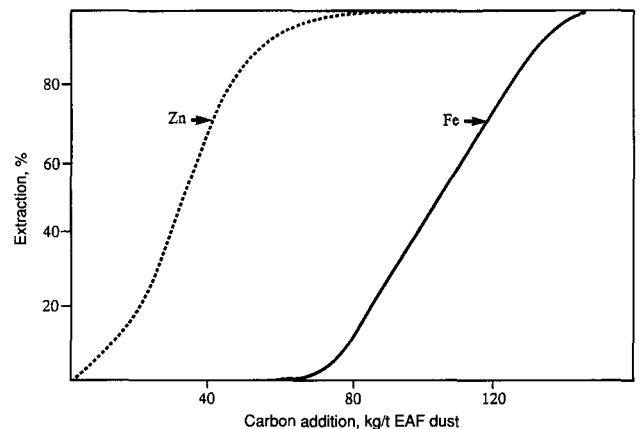

Figure 2—Predicted effect of carbon addition on the extraction of zinc and iron from high-zinc EAF

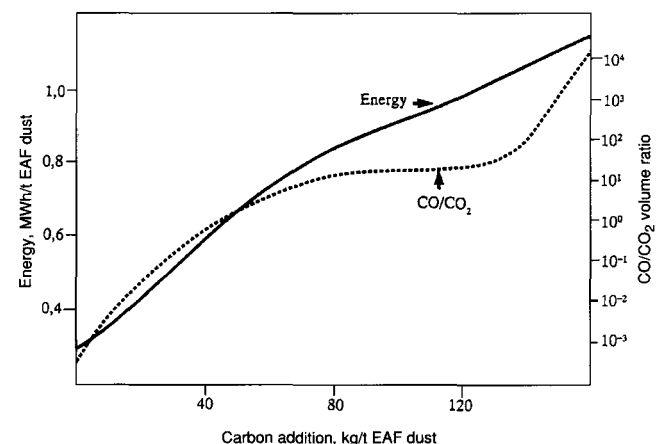

Figure 3—Predicted effect of carbon addition on the energy requirement and gas consumption of high-zinc EAF dust

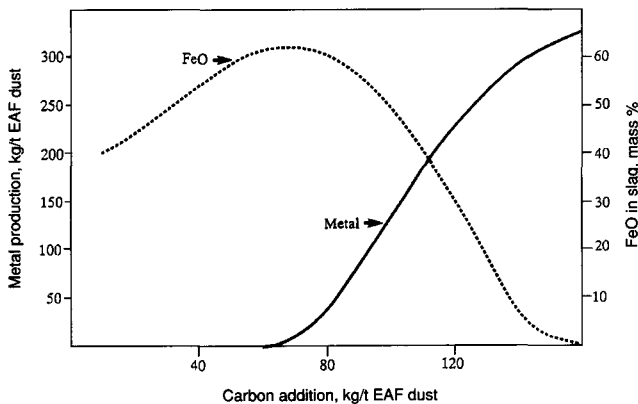

Figure 4—Predicted effect of carbon addition on metal production and slag composition of high-zinc EAF dust

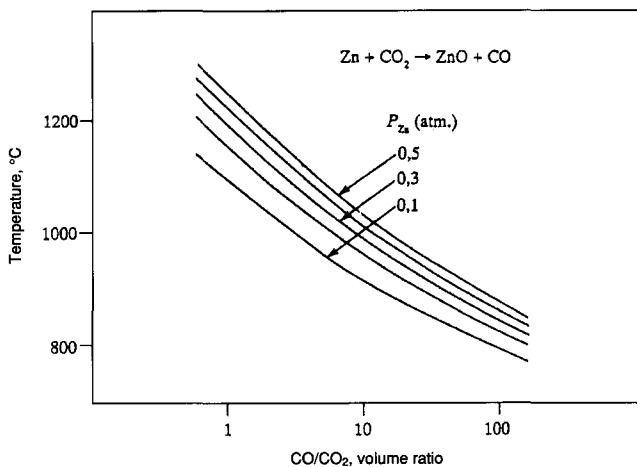

Figure 5—Temperature of the back-reaction of zinc with CO₂ at different CO/CO₂ ratios and zinc partial pressures in the off-gas

When a typical alloy-steel dust is smelted at 1500°C, a carbon addition of 170 kg per tonne of dust is required to extract most of the chromium (Figure 6). Ideal equilibrium simulations also predict a theoretical energy requirement of about 1,1 MWh per tonne of dust, which is significantly higher than the energy required to smelt high-zinc EAF dust (about 0,8 MWh/t). Also, the level of carbon monoxide in the off-gas and its CO-to-CO₂ ratio are much higher when alloy-steel dust is treated, because the iron oxide in the dust has also to be reduced if satisfactory recoveries of chromium to the metal are to be achieved. The low zinc content of typical alloy-steel dust does not warrant the condensation of zinc from the off-gas of the furnace.

EXISTING TECHNOLOGY

Although a large number of thermal processes for the treatment of steel-plant dusts have been developed to the pilot-plant stage, only a few technologies have found industrial application. The relatively high costs of the existing dust-treatment processes, and the technical and legal problems experienced with certain of these processes, have urged steel producers to consider alternative methods. In the USA, the EPA has instituted regulations that no longer permit disposal on landfill sites. This ban on landfilling, which was scheduled to take effect in August

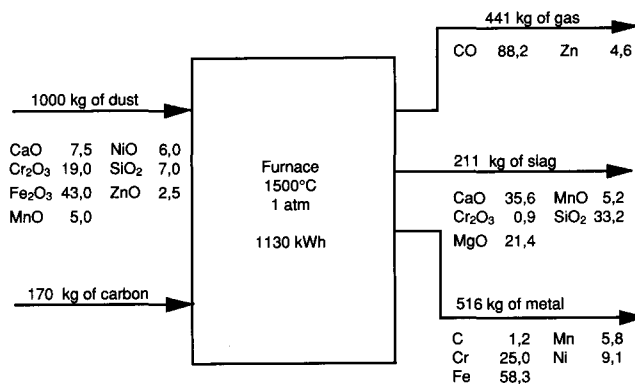

Figure 6—Predicted mass and energy balance for alloy-steel dust (all the analyses are given in percentages by mass)

1988, has already been postponed three times. The reason for the extensions of the deadline is to allow time for the development of the best-demonstrated available technology (BDAT) to treat steel-plant dusts and simultaneously recover most of their valuable metal contents. The major technologies for the treatment of EAF and alloy-steel dusts that are employed in Western Europe and the USA are described below.

Western Europe

The Waelz Kiln

The Waelz-kiln process³ is basically the only process used in Western Europe for the treatment of high-zinc EAF dust. A secondary oxidic dust is produced rich in zinc oxide, which is further processed in a conventional Imperial Smelting Furnace (ISF), where metallic zinc is recovered in a lead splash condenser. The Waelz-kiln technology is operated and marketed by Berzelius Umwelt-Service (BUS), formed in 1987 by Metallgesellschaft to develop the recycling of wastes from the metallurgical industry other than scrap, particularly dusts and sludges. BUS treats an annual total of 120 kt of EAF dusts in Duisburg and at the Aser plant, near Bilbao. The Aser plant is owned jointly by Indumetal, Metalquimica del Nervion, and BUS (30 per cent). EAF dusts from steelworks in northern Italy are processed in a Waelz kiln operated by Nuova Samim SpA at Ponte Nossa, near Bergamo. BUS has entered into a joint venture with Metaleurop to start a Waelz-kiln operation at Noyelles-Godault, in northern France. This operation is planned to come on line early in 1993. BUS is at present also exploring the market for their technology in the UK. The total annual capacity of the three existing plants in Western Europe is about 180 kt of EAF dust. The Waelz-kiln process is also operated in the USA and Japan. Currently, 14 kilns are reported to process EAF dust in Western Europe (3 kilns, 180 kt/a capacity), the USA (7 kilns, 450 kt/a capacity), and Japan (4 kilns, 200 kt/a capacity).

The Waelz kilns are operated in much the same way worldwide. Pelletized EAF dust mixed with a reducing agent such as coke breeze is fed into a gas-fired rotary kiln. Zinc, lead, and cadmium oxides are reduced carbothermically, volatilized, and subsequently re-oxidized in the freeboard of the kiln. Halide and alkali compounds

are also volatilized, and iron oxides are partially reduced. The re-oxidized metal vapours leave the kiln in the form of a flue dust, which is collected in a baghouse. This dust, which is called Waelz oxide, has a typical zinc content of 55 per cent. The slag product, which contains some metallic iron, meets the EPA Toxicity Characteristic Leaching Procedure (TCLP) test, and can be dumped safely or used as road fill. The Waelz oxide is hot-briquetted, and the briquettes are further processed in an ISF to recover metallic zinc and lead. At present, there are 5 ISF plants in Western Europe. They are located in Duisburg, Bristol, Noyelles-Godault (France), Porto Vesme (Italy), and Titov Veles (Yugoslavia).

The Plasmadust Process

The Plasmadust process was developed by SKF and has been operated in Landskrona, Sweden, since 1984. The company established for the operation of this process is called Scandust. In 1989, BUS obtained 25 per cent of Scandust's shares while the remaining shares are owned by SKF. The process was originally developed and built for the treatment of high-zinc EAF dusts. In 1988, the installation was converted to process alloy-steel dusts. The plant has a processing capacity of about 40 kt of alloy-steel dusts per annum.

The Plasmadust process is carried out in a coke-filled shaft furnace equipped with three 6 MW plasma generators. The d.c. non-transferred plasma devices are mounted on the tuyères of the shaft. Alloy-steel dust, pulverized coal, and fluxes are injected via the tuyères, together with superheated plasma gas. Temperatures of around 2500°C are reached in the cavity (raceway) formed in front of each tuyère. The high temperature and low oxygen partial pressure in the furnace permit the reduction of iron and chromium oxides, which is not the case for processes based on fuel-air such as the Waelz-kiln process. Hot metal containing iron, chromium, and nickel, and a non-hazardous slag are tapped at the lower part of the furnace. The dusts generated by the process itself contain about 20 per cent zinc oxide and are processed further in a Waelz kiln.

USA

Waelz Kiln and Flame Reactor

Horsehead Resources Development Company (HRD) is the principal company in the USA for the treatment of EAF dusts. HRD's history goes back to St. Joe Minerals Corporation, but its present ownership is 45 per cent Horsehead, 45 per cent BUS, and 10 per cent public. HRD has completed two new Waelz-kiln plants during the past four years, and now operates 7 kilns at 3 sites: Palmerton (PA), Calumet (IL), and Rockwood (TN). The annual EAF dust-processing capacity of the 7 kilns is 450 kt. The Waelz-kiln operation is similar to that practised by BUS in Europe (described earlier) but with one difference in that limestone is added as a flux, instead of silica sand.

HRD also operates a flame-reactor⁴ demonstration plant for the treatment of EAF dust in Monaca (PA). In 1991, HRD signed an agreement with North Star Steel to install and run a flame-reactor facility with a capacity of 30 kt of EAF dust per annum in Beaumont (TX). The demonstration plant consists of a water-cooled vertical cylinder divided

into a combustion and a smelting stage. In the first stage, carbon monoxide reducing gas is produced by partial combustion of natural gas with oxygen-enriched air. This first step is carried out in a cyclone burner at the top of the reactor. The hot reducing flame (flame temperature in excess of 2000°C) travels vertically downwards to the second stage, where EAF dust is injected pneumatically. The reactor has an internal diameter of 0.6 m and a height of 3 m. The average retention time in the reactor is about half a second, and feed rates of 1 to 2 t of EAF dust per hour are achieved. Metal oxides of zinc, lead, and cadmium are reduced, and the metals are volatilized at the temperature of the reactor (average temperature of about 1600°C). The off-gas leaving the reactor is post-combusted, the metal vapours are re-oxidized, and a crude zinc oxide is collected in a bag filter. Molten slag is tapped continuously from the reactor, and is sold or disposed of. HRD claim that there is little to choose between their flame-reactor and the Waelz-kiln technologies. Most of the zinc oxide product of HRD is processed further to zinc metal at their electrothermic zinc plant in Monaca (PA).

Other Thermal Processes

Since 1978, the Inmetco process⁵ has been operating in Elwood City (PA), using alloy-steel dusts and other oxidic wastes from the steel industry. In 1990, Inmetco processed over 55 kt of oxidic wastes and recovered about 20 kt of remelt alloy. The process consists of three steps, i.e. pelletizing of waste materials with coal fines, then reduction of pellets in a rotary-hearth furnace (RHF), and production of liquid metal in a submerged-arc furnace. Green pellets are fed direct into the gas-fired RHF, which is operated at a temperature of about 1250°C. Zinc, lead, and cadmium are evaporated, re-oxidized, and collected in a bag filter. The highly metallized pellets leaving the RHF are transferred hot into a submerged-arc furnace, where molten metal containing iron, chromium, and nickel is tapped and cast into pigs, which are recycled by stainless-steel producers. The non-hazardous slag is dumped or used as road fill.

The Tetronics plasma-arc process⁶ was developed in the late 1970s by Tetronics Research and Development (TRD) in the UK, and was demonstrated during 1987/1988 for the smelting of EAF dust in a collaborative effort by Bethlehem Steel Corporation (Bethlehem, PA) and TRD. The demonstration trials were funded by the Centre for Metal Production (CMP), Pittsburgh (PA), and 22 US steel producers. The process was subsequently marketed by International Mill Service (IMS), and in 1989 two commercial plants were installed in the USA. The first plant, at Florida Steel, Jackson (TN), with an annual capacity of 6 kt of EAF dust, was later upgraded to 9 kt/a. The second installation, at Nucor-Yamato Steel, Blytheville (AR), has a capacity of 12 kt/a. EAF dust and coke fines are fed through ports located in the roof of a cylindrical d.c. plasma-arc furnace. Electrical energy is supplied via a central graphite electrode. The zinc, lead, and cadmium oxides contained in the EAF dusts are reduced selectively and vaporized, and a non-hazardous slag rich in iron oxide is tapped periodically from the furnace. Gases are withdrawn from the furnace

continuously, and most of the metal vapours are condensed and captured in an ISP zinc splash condenser.

The Elkem process⁷ for the treatment of EAF dusts is based on the Elkem multi-purpose furnace (EMPF) in combination with an ISP zinc splash condenser. The EMPF is an air-tight, three-phase furnace equipped with a thermal oil-cooling system to achieve a frozen-slag lining. Elkem a/s markets its EMPF technology through Elkem Technology. To date, one EMPF has been built at Laclede Steel, Alton (IL). The furnace has a rating of 10 MW and an annual designed capacity of 40 kt of EAF dust. Construction started in 1989 and was completed in the third quarter of 1991. The process was scheduled to reach full operational status and capacity in the middle of 1992. The Elkem process is similar to the Tetronics process described earlier. The main differences are that a three-phase slag-resistance furnace is used instead of a d.c. open-arc furnace, and that briquettes are employed instead of unagglomerated feed.

ENVIROPLAS PROCESS

Description

The Enviroplas process was developed at Mintek for the smelting of solid wastes from the metallurgical industry, especially slags and dusts containing zinc oxide. The production of environmentally acceptable, non-toxic slags, and the recovery of zinc and other valuable metals from these waste materials, have been studied since 1987 using d.c. transferred plasma-arc technology. The development of this technology started at Mintek in 1979 for the smelting of ferrochromium, and has been implemented successfully at a scale of 40 MVA by Middelburg Steel & Alloys. To date, a total of about 100 t of lead blast-furnace slags and steel-plant dusts have been processed at the Mintek pilot plant. The plasma-arc pilot-plant equipment includes four furnaces, which are operated at power levels between 20 kW and 1 MW. The equipment has been described in detail elsewhere⁸. A schematic diagram of the 1 MW pilot plant is shown in Figure 7.

The 1 MW facility consists essentially of a d.c. power supply, a feed system, a plasma-arc furnace, a gas-cleaning system, and instrumentation for control and data logging. The water-cooled furnace is operated with a single graphite electrode as the cathode and a molten bath as the anode. The return electrode consists of several steel rods built into the hearth refractories and connected at their lower ends to a steel plate that is further linked to the anode cable. The feed is supplied to the furnace at a controlled rate through the central hole in the electrode, or via feed ports in the roof of the furnace. Molten slag and metal are tapped intermittently, and gases are withdrawn from the furnace continuously. The off-gas system is designed to ensure complete combustion of the carbon monoxide and metallic vapours produced in the furnace. Combustion air is drawn in at the off-gas port of the furnace and at the bottom of the combustion chamber.

Testwork

The suitability of the Enviroplas process for the smelting of zinc-bearing alloy-steel dusts was demonstrated during a 5-day continuous campaign, carried out in 1990, on the 1 MW pilot plant. Pre-mixed feed consisting of alloy-steel dust and anthracite was charged to the furnace via the central hole in the graphite electrode. The anthracite-to-dust ratio in the feed was selected to reduce the iron, chromium, nickel, zinc, and lead oxides in the dust to their respective metals. Slag and metal were tapped from the furnace when about 500 kg of dust and anthracite had been reacted, i.e. at 2- to 3-hourly intervals. The gas containing zinc and lead was burnt in the combustion chamber, and a mixed oxide of zinc and lead was recovered in the bag filter.

Alloy-steel dusts from three different sources were employed during the trials. The averaged analyses (weighted averages) of these dusts were as follows: 42,1 per cent Fe_2O_3 , 15,1 per cent Cr_2O_3 , 2,7 per cent NiO , 21,2 per cent ZnO , and 0,7 per cent PbO , the remainder being mainly CaO , SiO_2 , and MgO . Anthracite with a fixed carbon content of 77,4 per cent was used in the proportion of 290 kg per tonne of alloy-steel dust. The furnace was operated at power levels of about 500 kW and at feed rates of around 250 kg/h. The feed rate for a selected power level was calculated from the theoretical energy requirement and from the measured heat losses from the furnace. At a designed operating temperature of 1550°C, the theoretical energy requirement was determined to be 1,08 MWh per tonne of feed mixture, or 1,39 MWh per tonne of alloy-steel dust. The rate of the heat losses measured during the campaign was around 250 kW, i.e. about half of the energy supplied to the furnace was lost as heat dissipated through the furnace walls and roof. Expressed as a percentage of the power input, the rate of heat losses is expected to decrease when the operating power is increased, as experienced during other smelting processes tested at the Mintek pilot plant. The tapping temperatures were measured with an optical pyrometer. The average of these measurements was about 1560°C, which was very close to the designed temperature of 1550°C.

The ferro-alloys produced contained an average of 66,0 per cent iron, 19,1 per cent chromium, 3,4 per cent nickel, and 1,8 per cent silicon. Carbon, sulphur, and phosphorus,

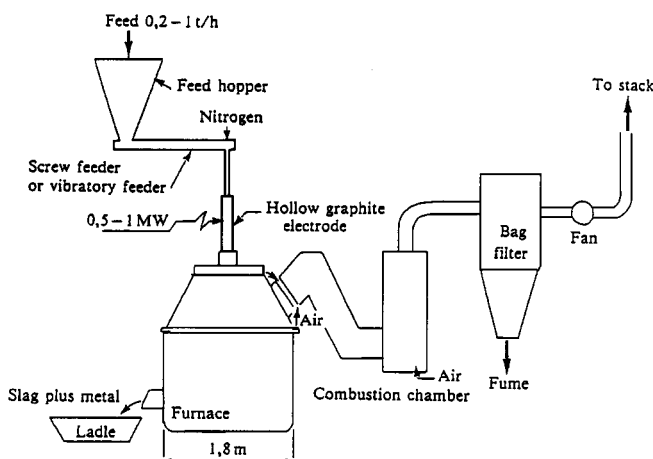

Figure 7— Schematic diagram of the Mintek 1 MW plasma-arc furnace

i.e. important elements with regard to recycling, were analysed at 5,3, 0,06, and 0,04 per cent respectively. Because of the relatively small quantities involved, no problems are envisaged with regard to contamination when this ferro-alloy is recycled to steelmaking furnaces. The average composition of the slags produced was as follows: 38,7 per cent SiO₂, 23,2 per cent CaO, 20,3 per cent MgO, 3,7 per cent Cr₂O₃, 0,09 per cent NiO, and 0,02 per cent ZnO. Only about 5 per cent of the chromium in the dust fed to the furnace was retained in the slag, while less than 1 and 0,1 per cent respectively of the nickel and zinc inputs reported to the slag. The fumes produced contained on average 56,3 per cent ZnO, 7,9 per cent MgO, 8,0 per cent SiO₂, and smaller quantities of Fe₂O₃, Cr₂O₃, and NiO. About 5 per cent each of the iron, chromium, and nickel charged to the furnace passed into the gas stream.

In 1988, testwork was carried out on the 1 MW pilot plant on the smelting and fuming of zinc-containing lead blast-furnace slag. Small-scale trials were conducted during 1989 on the smelting of EAF dust (high-zinc carbon-steel dust) in the 50 kW plasma-arc furnace at Mintek. The results of this testwork on lead blast-furnace slag and EAF dust have been reported previously⁹.

Advantages of the Enviroplas Process

At present, the dominant technology worldwide for the treatment of EAF dust is the Waelz-kiln process, while the main technologies employed in Western Europe and the USA for alloy-steel dusts are the Plasmadust and Inmetco processes. The Waelz-kiln, Plasmadust, and Inmetco processes are well established and achieve the desired results. However, the installations are large and capital-intensive and, because their annual processing capacities are between 40 and 80 kt of steel-plant dusts, they have to rely on dusts from several mini-mills. (A typical mini-mill produces about 5 kt of EAF dust per annum.)

During the past few years, new thermal processes for the treatment of steel-plant dusts have been developed. They are targeted at smaller annual processing capacities of 5 to 40 kt of dusts, and at the direct production of metallic zinc from zinc-bearing EAF dusts. The Tetronics, Elkem, and Enviroplas processes fall into this category of new developments. Compared with the Elkem process, the Enviroplas process has the inherent advantages of a d.c. plasma-arc furnace over an a.c. slag-resistance furnace, which include the following: reduced electrode consumption, symmetrical heat distribution, and a high degree of operational control. The graphite electrode is not in contact with the molten slag or metal, and hence accurate carbon addition to the process is possible. The plasma-arc furnace generates most of its heat between the tip of the electrode and the molten bath, and its power is not limited by the electrical conductivity of the slag. No fluxes are required to stay within the constraints of sufficient slag resistance.

The main difference between the Tetronics and Enviroplas plasma-arc systems lies in the charging practice. In the Enviroplas process, the feed is supplied to the furnace via the central hole of the graphite electrode while, in the Tetronics process, feed ports located in the roof are employed. Feeding through the hollow graphite electrode

offers the advantage that the fine steel-plant dust is rapidly absorbed into the molten slag. The vapour products, zinc and lead, leaving the furnace do not move through feed materials falling down from feed ports in the roof, thus minimizing contamination and elutriation or carry-over of the feed. The charge is delivered direct into the high-temperature reaction zone under the electrode.

Consequently, the heat transfer to drive the endothermic reactions is very efficient, and high reaction rates can be achieved. On the other hand, the supply of cold feed through the hollow electrode allows the temperature in the arc-attachment area to be controlled and suppressed, which is necessary to limit the vaporization of unwanted species.

COMMERCIAL CONSIDERATIONS

The selection of a process for the treatment of steel-plant dust should be based on site conditions such as local environmental regulations, current transport and disposal costs, local electricity and fuel costs, and the volume and chemical composition of the dust. For example, a 2 MW on-site plasma-arc furnace could be the most cost-effective solution for the processing of around 10 kt of EAF dust per annum. Treatment and landfilling charges per tonne of EAF dust, to be paid by steelworks, currently range from R200 to R300 in Western Europe, and in the USA fees of over R500 have been reported. On-site treatment of EAF dust containing more than 15 per cent zinc is believed to be economic when metallic zinc is produced direct from the dust using a condenser with a satisfactory zinc recovery (more than 80 per cent). Upgrading of the dust to a high-zinc dust (50 to 60 per cent zinc), and the sale of this dust to a zinc producer or reduction of the dust to form metallic zinc, are not usually economic in the on-site processing of this low-grade material.

A preliminary economic analysis of the Enviroplas process was conducted to provide an estimate of the costs and credits involved. An annual throughput of 18 kt of EAF dust was selected as the basis for the cost estimate. The following assumptions were made:

Zinc content of dust	20%
Thermal efficiency of furnace	70%
Zinc-condensing efficiency	90%
Operating availability	85% (7446 h per annum)
Zinc market price	R4000 per tonne
Electricity, unit cost	R95 per megawatt-hour
Electrode, unit cost	R6700 per tonne
Electrode consumption	2 kg per tonne of dust
Metallurgical coke, unit price	R230 per tonne.

The theoretical energy requirement for the selective reduction of EAF dust containing 20 per cent zinc (reduction of the zinc and lead oxides and minimal reduction of the iron oxide) is about 0,8 MWh per tonne of dust. The furnace needs to be operated at a power level of 3 MW and a feed rate of about 2,5 t of dust per hour. The estimated outside diameter and overall height of the furnace are 3,5 m and 3,8 m respectively. The capital costs for an on-site plant to treat 18 kt of EAF dust per annum were calculated to be 12 million rands. The main items involved in this cost figure were those for the plasma-arc furnace, a

lead splash condenser and bag filter, a feed system, product-handling equipment, buildings, utilities, and instrumentation. It is emphasized here that to date the only pilot-plant work carried out at Mintek has been at the 500 kW level, in which the zinc vapours were combusted to zinc oxide fume and collected in a bag filter, i.e. the lead splash condenser part of the Enviroplas process for the direct recovery of metallic zinc still needs to be demonstrated.

The operating costs (excluding capital recovery) for a plant of 18 kt/a are estimated at R320 per tonne of dust processed. These costs are based on experience gained from the pilot-plant tests and on thermodynamic simulations of the process. The major components are electricity and labour (6-man shift) at about 40 and 30 per cent of the operating costs respectively. Other operating costs include those of metallurgical coke, refractories, graphite electrodes, auxiliary power, and maintenance. Credits were computed at R540 per tonne of dust, indicating a gross profit of R220 per tonne of dust treated. In the calculation of these credits, the zinc-lead product was given a value based on the current market price of zinc, reduced by 25 per cent to take the removal of troublesome impurities into account. It should be emphasized that the overall economics are extremely sensitive to the zinc content of the dust, the market value of zinc, electricity and labour costs, and plant capacity.

A similar economic evaluation of the treatment of a typical alloy-steel dust (containing 12 per cent chromium and 5 per cent nickel) indicated capital costs of around 10 million rands for a 3 MW facility capable of treating about 10 kt of alloy-steel dust per annum. Operating costs and credits were estimated at R470 and R1000 respectively per tonne of dust, giving a gross profit of R530 per tonne of dust treated. Standard ferro-alloy prices, discounted by 25 per cent, were used in the calculation of credits for the metal product. The assumed recoveries of chromium and nickel were 90 and 95 per cent respectively.

It appears from this preliminary cost analysis that plants for the treatment of EAF dust and alloy dust are profitable, even without taking account of the disposal costs that would no longer be necessary. However, the cost figures should not be generalized, and individual steel companies would need specific cost studies to determine the profitability of the Enviroplas process for dust treatment. Discussions have already been initiated with several steel companies to analyse the technical and financial aspects of on-site dust-treatment plants and of larger-scale centralized facilities serving a number of steelworks. A technical proposal, a budget price, and a preliminary financial analysis are provided.

FURTHER TECHNICAL DEVELOPMENTS

Further technical developments are required for the Enviroplas process, particularly in the area of zinc condensing. Following detailed discussions with both the suppliers and the users of zinc condensers, it became evident that the combination of a Mintek d.c. plasma-arc furnace and an ISP type of lead splash condenser should justify the further development of this new technology as a

cost-effective alternative to existing processes for the treatment of steel-plant dusts. Since the carry-over of dust to the condenser, and kinetic phenomena such as the back-reaction of zinc with carbon dioxide, cannot be modelled accurately, demonstration-scale testwork is required to prove the perceived benefits that can be attained from a combination of the two established unit operations. Mintek's steel-plant dust programme is at present focused on the design and installation of a demonstration-scale plant including a lead splash condenser to progress towards refining of the process economics and ultimate commercialization.

CONCLUSIONS

Steel-plant dusts are listed by the Environmental Protection Agency (EPA) as hazardous waste materials because they contain toxic constituents such as lead, cadmium, and hexavalent chromium. A number of thermal-processing technologies exist, and new ones are being developed for the treatment of steel-plant dusts. In the Enviroplas process, fine dusts are charged direct to a plasma-arc furnace via the central hole of a graphite electrode. Disposable slags are produced, and at the same time valuable byproducts, such as ferro-alloys containing chromium and nickel, and fumes high in zinc oxide are recovered. At present, Mintek is developing the Enviroplas further to recover metallic zinc direct in a lead splash condenser, and so to provide a cost-effective alternative process for the treatment of steel-plant dusts.

ACKNOWLEDGEMENT

This paper is published by permission of Mintek.

REFERENCES

1. BARCZA, N.A., and NELSON, L.R. Technology for treatment of steel-plant dusts. *World Steel Review*, vol. 1, no. 1, Spring 1991.
2. JONES, R.T. Computer simulation of pyrometallurgical processes. *APCOM 87. Proceedings of the Twentieth International Symposium on the Application of Computers and Mathematics in the Mineral Industries*. Johannesburg, South African Institute of Mining and Metallurgy, 1987. vol. 2, pp. 265-279.
3. KOLA, R. The treatment of EAF dust in Europe. *Proceedings of an international conference organized by the International Lead and Zinc Study Group Sub-Committee on Recycling*. Rome, Jun. 1991. pp. 279-295.
4. WU, L., and THEMELIS, N.J. The flash reduction of electric arc furnace dusts. *J. Metals*, Jan. 1992. pp. 35-39.
5. BAUER, K.H., et al. Recycling of iron and steelworks' wastes using the Inmetco direct reduction process. *Metallurgical Plant and Technology International*, vol. 4, 1990. pp. 74-87.
6. CHAPMAN, C.D., et al. Tetronics plasma process for recovery of zinc, lead and other metals from secondary sources. *Proceedings of the Recycling of Metalliferous Materials Conference*. London, Institution of Mining and Metallurgy, 1990. pp. 47-55.
7. AUNE, J. Elkem's high temperature metals recovery system. *CMP Symposium on EAF Dust Treatment*, Pittsburgh PA, Jan. 1992.
8. BARCZA, N.A., CURR, T.R., DENTON, G.M., and HAYMAN, D.A. Mintek's role in the development of plasma-arc technology based on a graphite cathode. *ISPC-9*. Sep. 1989.
9. SCHOUKENS, A.F.S., NELSON, L.R., and BARCZA, N.A. Plasma-arc treatment of steel-plant dust and zinc-containing slag—theoretical and practical considerations. *Proceedings of an international conference organized by the International Lead and Zinc Study Group Sub-Committee on Recycling*. Rome, Jun. 1991. pp. 361-370.